

THIS DRAWING IS UNPUBLISHED. RELEASED FOR PUBLICATION 2008
 © COPYRIGHT 2008 BY TYCO ELECTRONICS CORPORATION. ALL RIGHTS RESERVED.

OPTIMIZED FOR F/UTP CABLES	1711343-2
OPTIMIZED FOR S/FTP and F/FTP CABLES	1711343-1
NOTE	PN-DASH

OPTIONS AFTER PRODUCT APPLICATION:
 RIGHT CABLE APPLICATION:

GENERAL VIEW:
 BEFORE TERMINATION

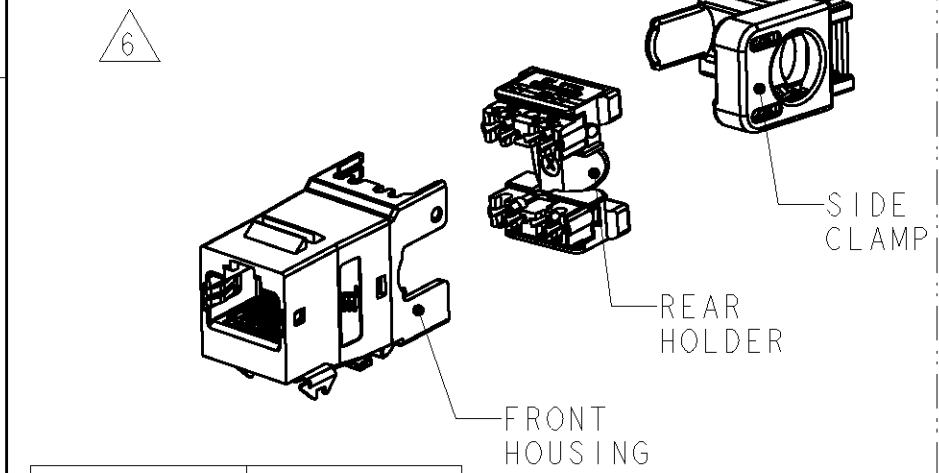

AS SHOWN	1711343-1
COMMENTS	PN

LEFT CABLE APPLICATION:

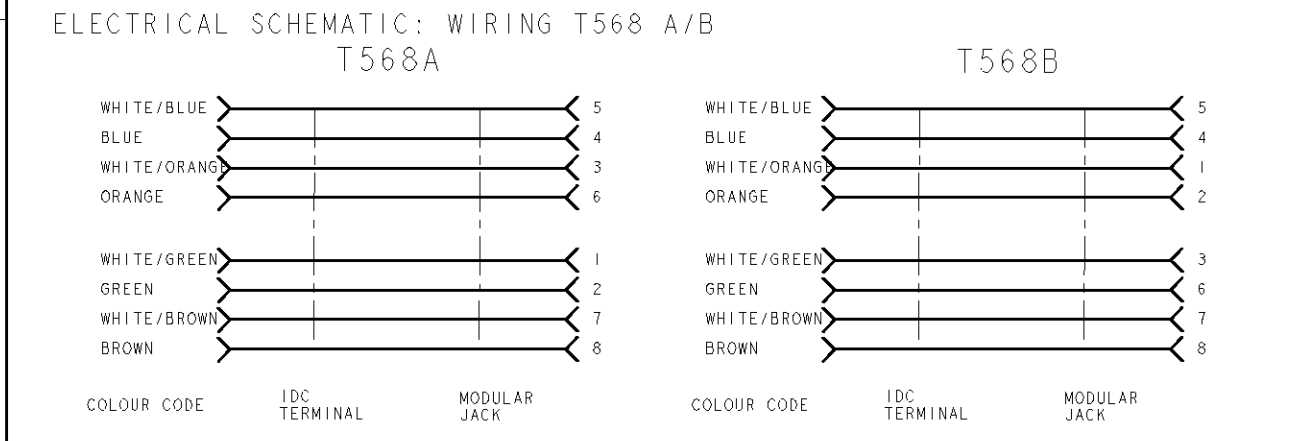
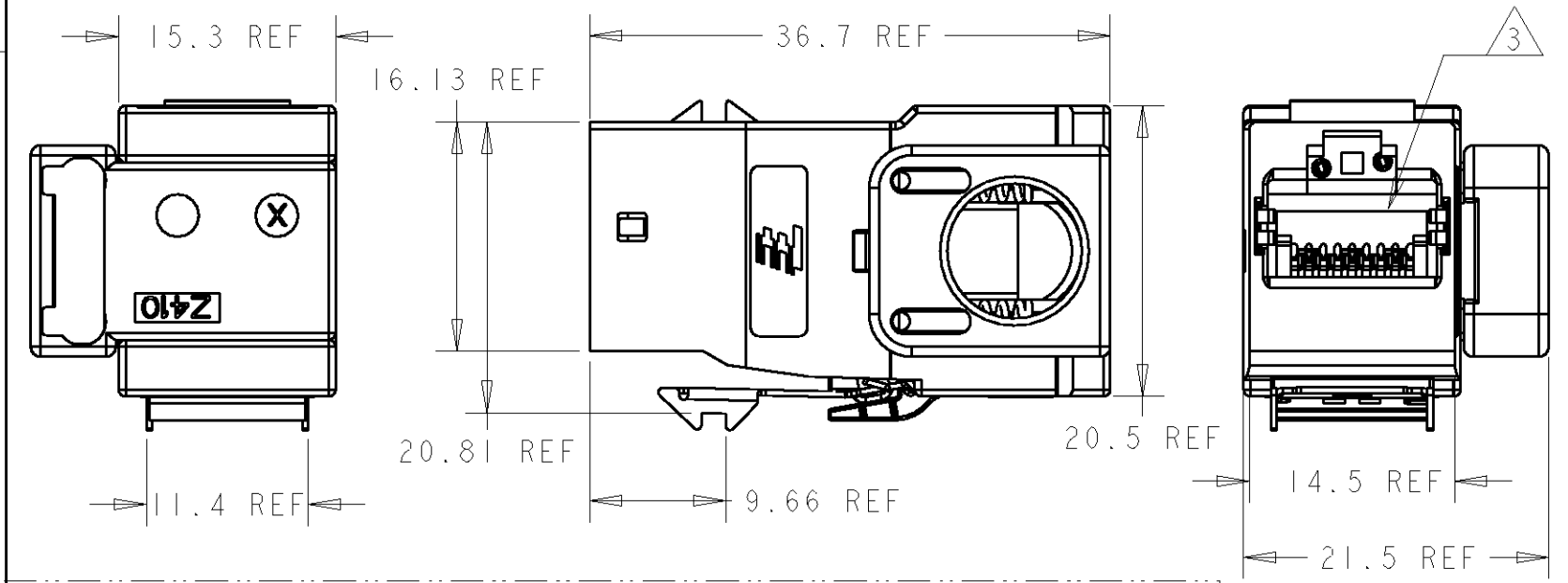
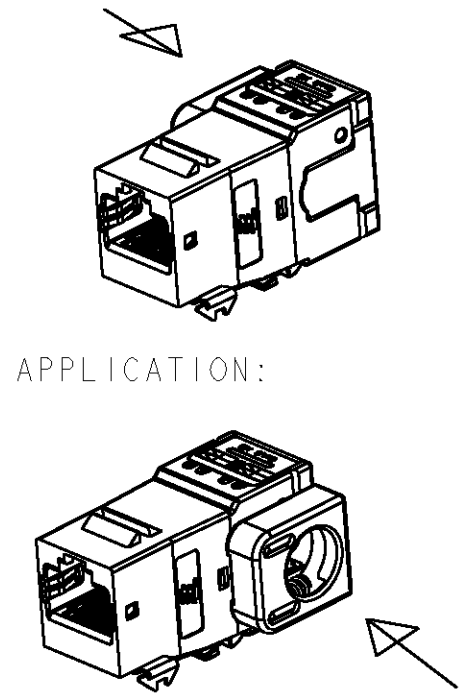

LOC	DIST	REVISIONS					
		P	LTR	DESCRIPTION	DATE	DWN	APVD
1K	2		A	FIRST ISSUE	08NOV2006	ACG	JS
			B	ECR-08-006695	13MAR2008	ACG	JS
			BI	ADDED DASH 2	14NOV2008	ACG	JS

- 1 MATERIAL:
- FRONT AND REAR HOUSING, CABLE CLAMP: ZAMAK 5. (Z410).
 - IDC CONNECT BLOCK, DUST COVER AND LACING FIXTURE: POLYCARBONATE NATURAL.
 - CUTTING BLADE, SPRINGS, LATCH AND SHIELD CONTACT POINT: STAINLESS STEEL.
 - JACK CONTACTS: BERYLLIUM COPPER, PLATED WITH 1.27 um MINIMUM THICK GOLD IN LOCALIZED AREA AND 3.81 um MINIMUM THICK MATTE TIN IN SOLDER AREA OVER 1.27 um MINIMUM THICK NICKEL UNDERPLATE.
 - IDC TERMINALS: PHOSPHOROUS BRONZE, PLATED WITH 3.81 um MINIMUM THICK BRIGHT MATTE TIN OVER 1.27 um MINIMUM THICK NICKEL UNDERPLATE.
2. AMP-TWIST-6S SL JACK WILL TERMINATE:
- SOLID CONDUCTORS: 22-24 AWG.
 - STRANDED CONDUCTORS: 24-26 AWG.
 - MAX. INSULATION DIAMETER: Ø1.60 mm.
 - MAX. CABLE JACKET: Ø9.00 mm.
- 3 CAVITY ACCORDING TO IEC 60603-7-5 Ed. 1.0
4. MOUNTING PANEL THICKNESS 1.47-1.60 mm. (SEE SUGGESTED CUTOUT).
- 5 THESE TWO SUGGESTED CUTOUT OPENINGS ARE USED IN TANDEM WITH DUAL FRONT AND BACK CUTOUTS.
- 6 PACKAGING: ACCORDING TO SPEC. 107-93003. ONE SUB-ASSY FRONT HOUSING + ONE SUB-ASSY REAR HOLDER + ONE SUB-ASSY SIDE CLAMP AND ONE 1 SHEET PER POLYBAG.
7. REFER TO 411-93014 FOR TERMINATION INSTRUCTIONS USING SL SERIES TOOL TERMINATION: SL SERIES TOOL PN 1901551-1.
8. DIMENSIONS SHOWN ARE FOR REFERENCE ONLY.

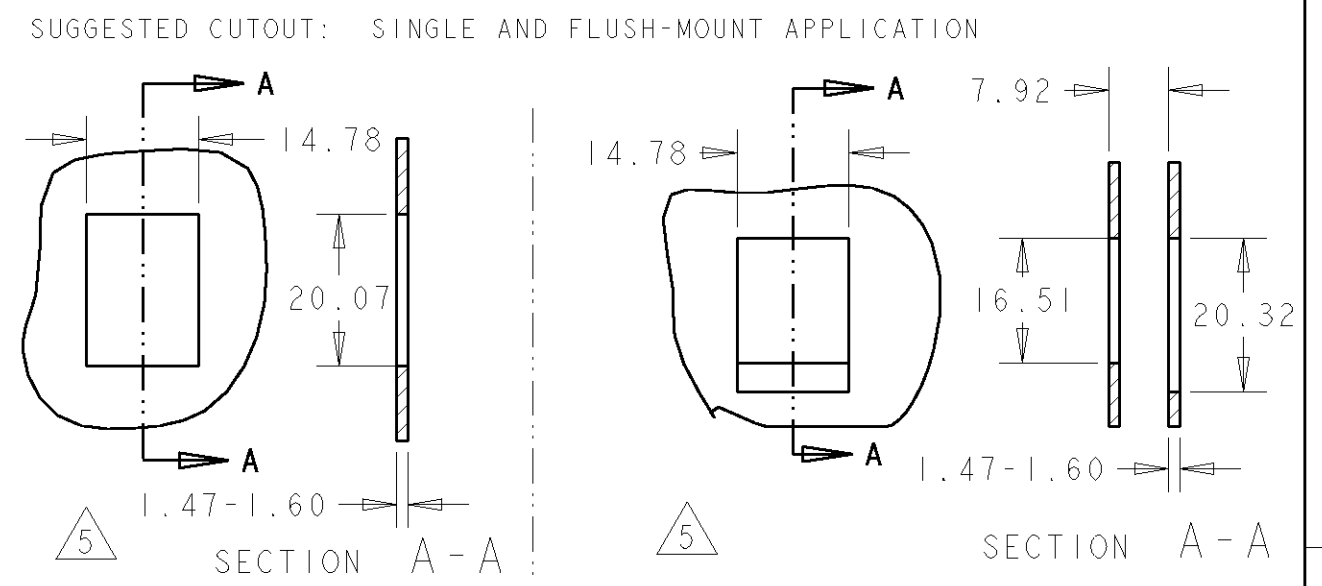

THIS DRAWING IS A CONTROLLED DOCUMENT FOR TYCO ELECTRONICS CORPORATION IT IS SUBJECT TO CHANGE AND THE CONTROLLING ENGINEERING ORGANIZATION SHOULD BE CONTACTED FOR THE LATEST REVISION.

DWN	08NOV2006	Tyco Electronics AMP España, S.A. Barcelona, Spain.
CHK	A. CARRERAS	
CHK	J. SANABRA	
APVD	J. SANABRA	
PRODUCT SPEC		NAME
108-93003		
APPLICATION SPEC		SIZE
411-93014		
WEIGHT		CAGE CODE
-		00779
MATERIAL		DRAWING NO
-		1711343
FINISH		RESTRICTED TO
-		-
CUSTOMER DRAWING		SCALE
-		1:1
		SHEET
		1
		OF
		REV
		BI